





## Opal Progressive Pull Out Kitchen Set

### SPECIFICATION

WELS RATING	6 STAR 4.5L/MIN
WATERMARK LICENSE	WM-060073
TEMPERATURE RATING	MIN 1°C-MAX 75°C
PRESSURE RATING	MIN 150KPa-MAX 500KPa

### FINISH

	GRAPHITE NR252008GR		BRUSHED NICKEL NR252008BN
	BRUSHED BRONZE NR252008BZ		BRUSHED GOLD NR252008BG

### MAINTENANCE AND CARE

All surfaces should be cleaned with mild liquid detergent or soap and water.

Do not use cream cleaners or citrus based cleaning products, as they are abrasive.

Use of unsuitable cleaning agents may damage the surface. Any damage caused in this way will not be covered by warranty

### PACKING INCLUDES

- 1x pull out sink spout
- 1x hand wheel
- 1x base ring
- 1x counter weight
- 1x triangular support
- 1x extension hose
- 2x flexible hose

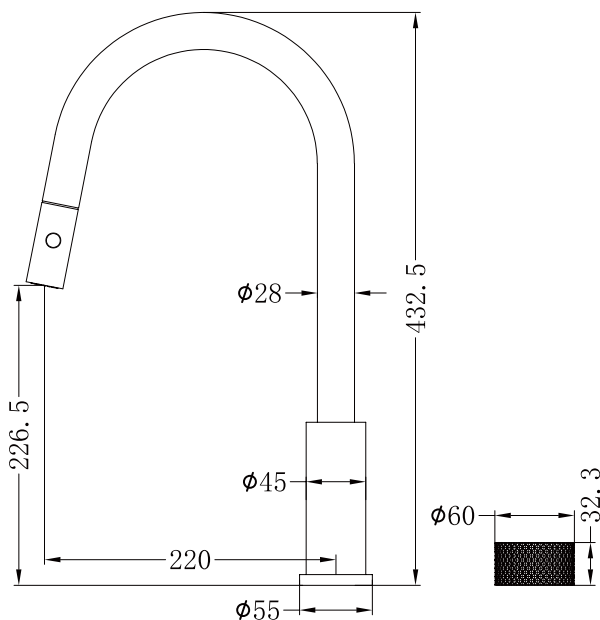

Dimensions are nominal measurements only.



Versions: V1

## Installation Instruction

1

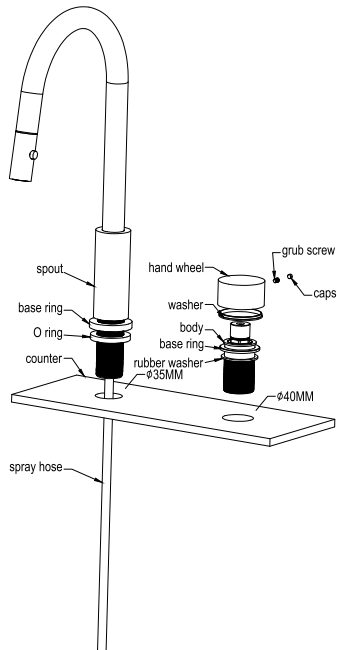

1. Drill a 35mm (for spout) and a 40mm (for mixer) through-hole on the counter. (The counter thickness must be between 20mm to 40mm)  
The recommended distance of the two holes is 200mm, reference to below diagram.
2. Remove all fitting parts on the thread pipe for both spout part and mixer part.  
Put on base ring for spout part, then put spout part and mixer part through the two holes.

2

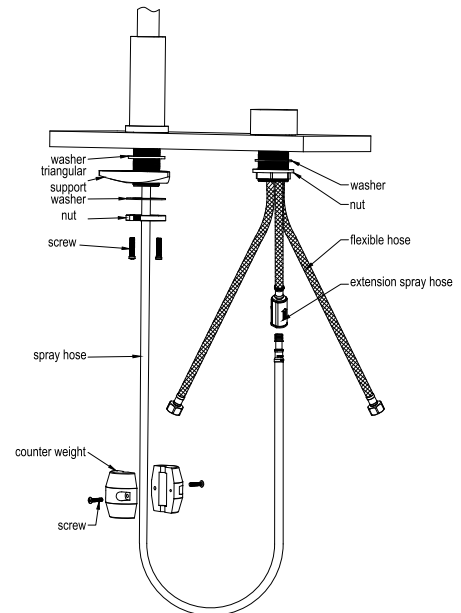

3. Slide rubber washer, triangle plate and steel washer and lock nut onto spout part in a row according above diagram. Then slide rubber washer and nut onto mixer part.
4. Screw on extension spray hose, hot and cold flexible hoses onto mixer part according to below diagram.
5. Connect pull out hose to extension hose by quick joint.
6. Install counter weight onto pull out hose firmly. The recommended installation height of weight is 350mm from the counter bottom side, please reference to below diagram.

3

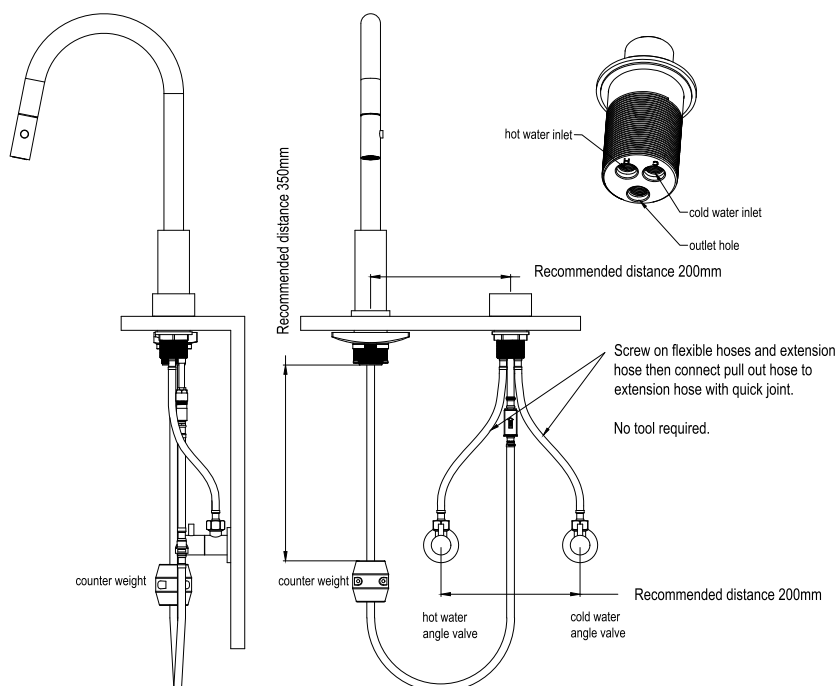

7. Check and test for leak.